



Robex 210LC-7

Standard Equipment

ISO standard cabin

- All-weather steel cab with all-around visibility
- Safety glass windows
- Rise-up type windshield wiper
- Sliding fold-in front window
- Sliding side window
- Lockable door
- Hot & cool box
- Accessory box & Ashtray

Computer Aided Power Optimization (New CAPO) system

- 2-power mode, 3-work mode, 2-user mode
- Auto deceleration & one touch deceleration system
- Auto warm up system
- Auto overheat prevention system

Heater & Defroster (7500 Kcal/hr, 30000 BTU/hr)

Self diagnostic system

Starting Aid (air grid heater), cold weather

Centralized monitoring

- LCD display
 - Engine speed
 - Clock & Error code
- Gauges
 - Fuel level gauge
 - Engine coolant temperature gauge
 - Hyd. oil temperature gauge
- Warning
 - Fuel level
 - CPU
 - Engine oil pressure
 - Engine coolant temperature
 - Hyd. oil temperature
 - Low battery
 - Air cleaner clogging
- Indicator
 - Power max
 - Preheat & Engine warming-up
 - One touch decel

Door and cab locks, one key

AM/FM radio and cassette

- Radio remote switch

Two outside rearview mirrors

Fully adjustable suspension seat with seat belt

Slidable joystick, pilot-operated

Console box tilting system(LH.)

Three front working lights

Electric horn

Batteries (2 x 12V x 100 AH)

Battery master switch

Removable clean out screen for oil cooler

Automatic swing brake

Removable reservoir tank

Fuel pre-filter with fuel warmer

Boom holding system

Arm holding system

Counterweight (3800kg, 8380lb)

Mono boom (5.68m, 18' 8")

Arm (2.92m, 9' 7")

Track shoes (600m, 24")

Track rail guard

Optional Equipment

Air-conditioner (5,000 kcal/hr, 20,000 BTU/hr)

FATC (Full Automatic Temperature Control)

Sun visor for cabin inside

Fuel filler pump (35 l/min, 9.5 US gpm)

Beacon lamp

Safety lock valve for boom cylinder with overload warning device

Safety lock valve for arm cylinder

Single acting piping kit (breaker, etc)

Double acting piping kit (clamshell, etc)

Quick coupler

Accumulator, work equipment lowering

12 volt power outlet (24V DC to 12V DC converter)

Electric transducer

TET LCA CLUSTER

CD Player

Travel alarm

Various optional Arms

- Super short arm (2.00 m, 6' 7")
- Short arm (2.40 m, 7' 10")
- Long arm (3.90 m, 12' 10")

Various optional Buckets (SAE heaped)

- Standard bucket (0.92 m³, 1.20 yd³)
- Narrow bucket (0.51 m³, 0.67 yd³)
- Narrow bucket (0.80 m³, 1.05 yd³)
- Light duty bucket (1.10 m³, 1.44 yd³)
- Light duty bucket (1.20 m³, 1.57 yd³)
- Light duty bucket (1.34 m³, 1.75 yd³)
- Heavy duty bucket (0.74 m³, 0.97 yd³)
- Heavy duty bucket (0.90 m³, 1.18 yd³)
- Heavy duty bucket (1.05 m³, 1.37 yd³)
- Rock bucket (0.87 m³, 1.14 yd³)
- Rock bucket (1.20 m³, 1.57 yd³)
- Slope fishing bucket (0.75 m³, 0.98 yd³)

Cabin FOPS/FOG(ISO/DIS 10262)

- FOPS(Falling Object Protective Structure)
- FOG(Falling Object Guard)

Cabin Roof-cover Transparent

Cabin lights

Track shoes

- Triple grousers shoe (700 mm, 28")
- Triple grousers shoe (800 mm, 32")
- Double grousers shoe (710 mm, 28")

Lower frame under cover

Pre heating system, coolant

Tool kit

Operator suit

Special cooling

- Air vent type side door
- Louver type side door

Low noise kit

Engine emergency control cable

Seat

- Adjustable air suspension seat
- Mechanical suspension seat with heater



■ Some of the photo may include optional equipment.

Robex CRAWLER EXCAVATOR Applied Tier 2 Engine

210LC-7 / 210LC-7 High-Chassis

Standard and optional equipment may vary. Contact your Hyundai dealer for more information. The machine shown may vary according to International standards. All US measurement rounded off to nearest pounds or inches.

HYUNDAI
HEAVY INDUSTRIES CO., LTD.
CONSTRUCTION EQUIPMENT

Head Office (Sales Office) 1 JEONHA-DONG, DONG-GU, ULSAN, KOREA
Tel (82) (52) 202-7970, 7729 Fax (82) (52) 202-7979, 7720

U.S. Operation Hyundai Construction Equipment U.S.A., Inc.
955 ESTES AVENUE, ELK GROVE VILLAGE, IL, 60007
Tel (1) 847-437-3333 Fax (1) 847-437-3574

European Operation Hyundai Heavy Industries Europe N.V.
VOSSENDAAL 11, 2440 GEEL, BELGIUM
Tel (32) 14-562200 Fax (32) 14-593405-06

PLEASE CONTACT

www.hyundai-ce.com

2008. 03 Rev 10.

HYUNDAI
HEAVY INDUSTRIES CO., LTD.

We build a better future

Built for Maximum Power, Performance, Reliability.

A new chapter in construction
equipment has now begun.
Making the dream a reality.



Photo may include optional equipment.

Operator's Comfort is Foremost. Wide Cab Exceeds Industry Standards.



Visibility

- Even more visibility than before, for safer, more efficient operating.

Excellent ventilation

- Ventilation has been improved by the addition of the larger fresh air intake system, and by providing additional air flow throughout the cab.
- Sliding front and side windows provide improved ventilation.
- A large sunroof offers upward visibility and additional ventilation.

Comfortable operator environment

- The control levers and seat can be adjusted to provide maximum operator comfort.
- The seat is fully adjustable for optimum operating position, reducing operator fatigue.
- Console boxes slide forward and backward for improved accessibility.
- The proportional pressure controls reduce unnecessary exertion while ensuring precise operation.
- Large windows allow excellent visibility in all directions.

Low noise design

- The Robex 7 series was designed with low operation noise in mind.
- Hyundai engineering helps to keep interior and exterior noise levels to a minimum.
- The cab's noise levels have been additionally reduced by improving the door seals for the cab and engine compartments.
- An insulated diesel engine compartment with sound-damping material also reduces noise.



1 Wide, Comfortable Operating Space 2 Steel Cover Sunroof
3 Dial Type Engine Speed Switch and Key Switch

Operating Environment

The best working conditions in a pleasant environment.

- 1 Centralized control panel
- 2 Horn button
- 3 Option button
- 4 Remote radio control
- 5 Travel lever
- 6 Cluster
- 7 One touch decel button
- 8 Hour meter
- 9 Travel pedal
- 10 Fully adjustable suspension seat
- 11 Safety lever
- 12 Power boost button
- 13 Joystick control lever
- 14 Air conditioner and heater controller

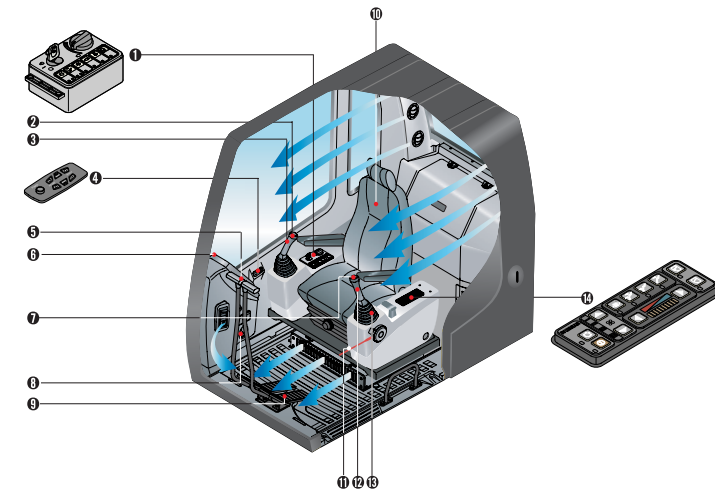

Rear Emergency Exit Window

Rear Exit Window is designed with easy exit for operator's safety.



Rise-up Wiper and Cabin Lights

Raise-up wiper has enhanced for the better front view. Cabin Lights enhances safety by brightly lighting the surroundings during night work(optional)



Wide Cab with Excellent Visibility

The cab is roomy and ergonomically designed with low noise level and good visibility. A full view front window and large rear and side windows provide excellent visibility in all directions.



Highly Sensitive Joystick and Easy Entrance

New joystick grips for precise control have been equipped with double switches. (Left: Power boost / One touch deceleration, Right: Horn/Optional)



Wide, Comfortable Operating Space

All the controls are designed and positioned according to the latest ergonomic research. Reinforced pillars have also been added for greater cab rigidity.



Remote Radio Control and Deluxe Cassette

Smooth Travel Pedal and Foot Rests



Improved Intelligent Display

Instrument Panel is installed in front of RH console box. It is easy to check all critical systems with easy-to-read indicators.



Easy-to-Reach Control Panels

Switches and other essential controls are located near the operator. This helps keep operator movement to a minimum, enhancing control with less operator fatigue.



Storage box and Cup Holder

An additional storage box and cup holder are located behind operator's seat, and it keeps food and beverages cool or hot.

Advanced hydraulic system

Advanced capo system

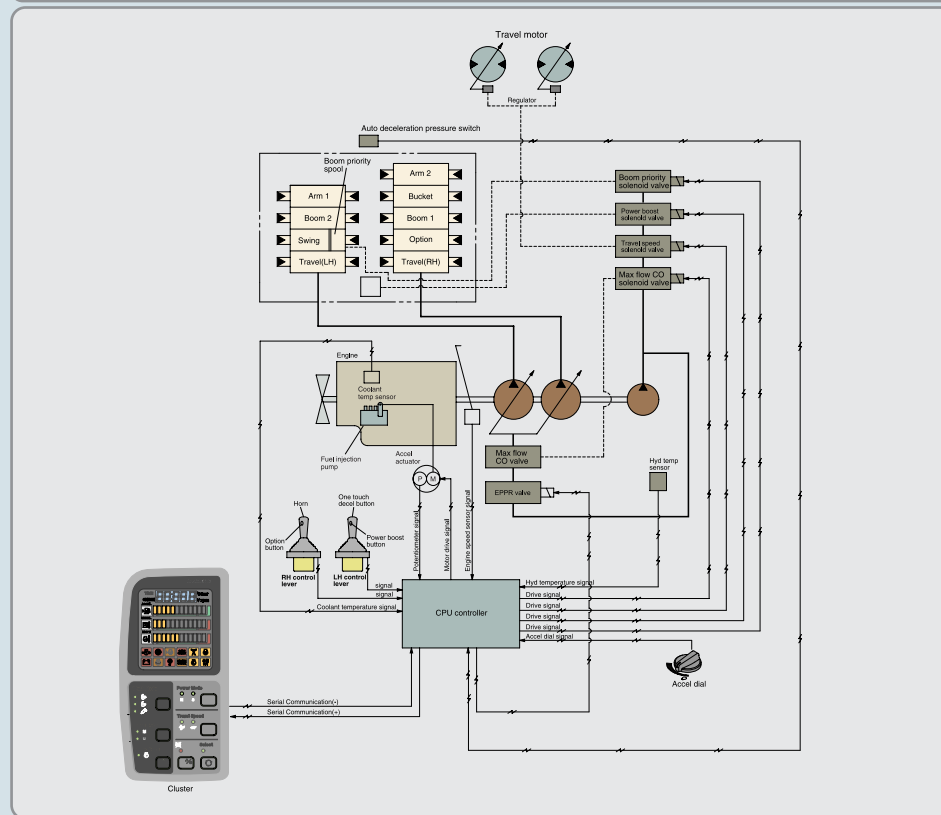

Advanced CAPO System

The Advanced CAPO (Computer Aided Power Optimization) system maintains engine and mutual pump power at optimum levels. Mode selections are designed for various work loads and maintaining high performance while reducing fuel consumption.

Features such as auto deceleration and power boost are included in the system.

The system monitors engine speed, coolant temperature, and hydraulic oil temperature. Contained within the system are self diagnostic capabilities, which are displayed by error codes on the cluster.

Self Diagnosis System

The CPU controller diagnoses problems in the CAPO system caused by electric and hydraulic malfunctions and displays them on the LCD monitor of the cluster by error codes. This controller has the capacity to identify 48 distinct types of errors. As the information from this device, such as engine rpm, main pump delivery pressure, battery voltage, hyd. temperature, and the state of all types of electric switches, provides the operator with a much more exact state of machine operating condition. This makes the machine easier to troubleshoot when anything does go wrong.

Arm Flow Regeneration System

Arm flow regeneration valve provides smooth arm operation without cavitation.

Boom & Arm Holding System

The Holding valves in the main control valve prevents the boom & arm from dropping over an extended period in neutral position.

One Touch Deceleration

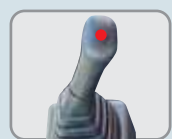

When the one touch deceleration button on top of LH joystick is pushed once, the engine rpm will be immediately down to low idle rpm.

Engine speed will be recovered to its preselected rpm in case the button is pushed once more.

Max. Flow Cut-off System

For precise control and finishing work, the Max. Flow Cut-off System reduces pump flow, thus allowing smooth operation.

Automatic Engine Overheat Prevention

If the engine coolant temperature gets too high, the CPU controller lowers the engine speed and cools the engine.

Anti Restart System

The new system protects the starter from restarting during engine operation, even if the operator accidentally turns the start key again.

New mode control system

POWER MODE

H mode: High power S mode: Standard power

WORK MODE

: Heavy duty work
 : General work
 : Breaker

USER MODE

M mode: Maximum Power
 U mode: Memorizing Operator's Preferable Power Setting



Power boost control System

When the power boost system is activated, digging power increases about 10%. It is especially useful when extra power is temporarily needed, for instance, when digging hard earth and rock, or if the bucket teeth are stopped by a stubborn tree root.

Automatic Warming-up System

After the engine is started, if the engine coolant temperature is low, the CPU controller increases the engine speed and automatically to warm up the engine more effectively.

Pump Flow Control System

In neutral position: Pump flow is reduced to a minimum to eliminate power loss.

In operation: Maximum pump flow is delivered to the actuator to increase the speed. With movement of the control lever, pump flow is automatically adjusted and the actuator speed can be proportionally controlled.

Hydraulic Damper in Travel Pedal

Improved travel control ability & feeling by shock reducing when starting and stopping.

Strong and Stable Lower Frame

Reinforced box-section frame is all welded, low-stress, high-strength steel.

It guarantees safety and resistance against external impact when driving on rough ground and working on wet sites through high tensile strength steel panels, with highly durable upper and lower rollers and track guards.

Long undercarriage incorporates heavy duty excavator style components.

X-leg type center frame is integrally welded for maximum strength and durability.



Track Rail Guide & Adjusters

Durable track rail guides keep track links in place. Track adjustment is made easy with standard grease cylinder track adjusters and shock absorbing springs.

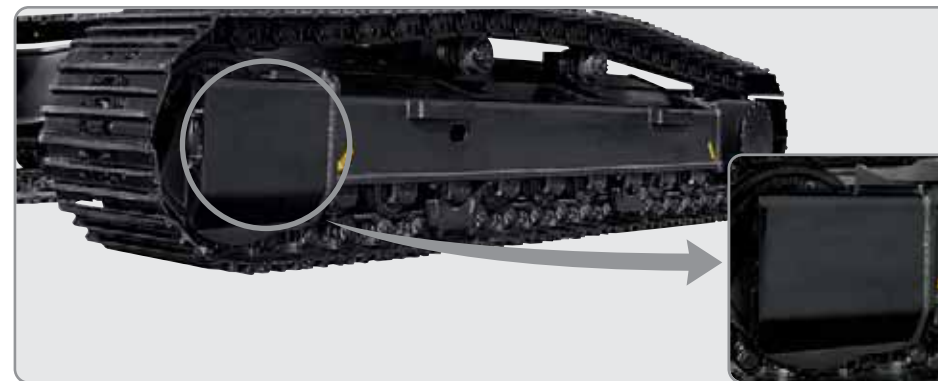

Powerful and Preciser Swing Control

Improved shock absorbing characteristics make stopping a precise and smooth action



Minimization of Shock and Vibration through Cab Mounting System

The application of Viscous Mounting to the cabin support provides the operator with a much improved ride.

The operator work efficiency will increase as the shock and noise level in the cabin decreases.

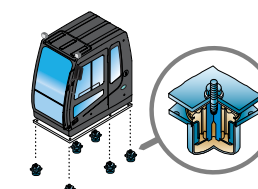

Increased higher performance

CUMMINS B5.9-C ENGINE

The six cylinders, turbo-charged, 4 cycle, charger air cooled engine is built for power, reliability, economy and low emissions.



A More Reliable Way To Reach You Dream.

The Cummins B5.9-C engine has been designed with 40% fewer parts than the competition. That means there's less that can go wrong when you need it most. It also means fewer parts to inventory. Repairs are simplified because no special tools are needed for maintenance. The weight of the machine is reduced without sacrificing strength.

The B5.9-C engine is capable of reaching emission standards without electronic engine controls. You get a proven power plant that meets ecological concerns, without paying a premium for technology you don't need.

Reinforced Bucket and Bucket Linkage

Sealed and adjustable bucket linkage provides less wear of pins and bushes

as well as silent operation. The design includes bucket link durability and anti wear characteristics. Additional reinforcement plates on cutting edge section. Reinforced bucket is made with thicker steel and additional lateral plate.





Durability of structure proven through FEM(Finite Element Method) analysis and long term durability test.

Photo may include optional equipment.



Easy to maintain engine components

The cooling and preheating system are provided for optimum and immediate operation, guaranteeing longer life for the engine and hydraulic components. Servicing of the engine and hydraulics is considerably simplified due to total accessibility.



Centralized Electric Control Box and Easy Change Air Cleaner Assembly

Electric control box and Air cleaner are centralized in one or the same compartment for easy service.



Side Cover with Left & Right Swing Open Type

Easy access to vital components gives unrestricted view of component allows easy maintenance and repair.



Large tool box for extra storage



Highly efficient Hydraulic Pump

Pump output and Hydraulic tank capacity have been increased. A pilot pump has been installed resulting in improved control sensitivity.



Engine

Model		Cummins B5.9-C	
Type		Water cooled, 4 cycle Diesel, 6-Cylinders in line, direct injection, Turbocharged, charge air cooled, Low emission	
Rated flywheel horse power	SAE	J1995 (gross)	150HP (112kW) / 1,950rpm
		J1349 (net)	143HP (107kW) / 1,950rpm
	DIN	6271/1 (gross)	152PS (112kW) / 1,950rpm
		6271/1 (net)	145PS (107kW) / 1,950rpm
Max. torque		62.6kgf-m (453lb-ft) / 1,500rpm	
Bore × stroke		102mm (4.02in) × 120mm(4.72in)	
Piston displacement		5,880cc (359 in ³)	
Batteries		2 x 12V × 100AH	
Starting motor		24V, 4.5kw	
Alternator		24V, 50Amp	



Hydraulic system

Main pump	
Type	Two variable displacement piston pumps
Max. flow	2 × 220 ℓ /min (58.1 US gpm / 48.4 UK gpm)
Sub-pump for pilot circuit	Gear pump
Cross-sensing and fuel saving pump system	
Hydraulic motors	
Travel	Two speed axial piston motor with brake valve and parking brake
Swing	Axial piston motor with automatic brake
Relief valve setting	
Implement circuits	330 kgf/cm ² (4,690 psi)
Travel	330 kgf/cm ² (4,690 psi)
Power boost (boom, arm, bucket)	360 kgf/cm ² (5,120 psi)
Swing circuit	240 kgf/cm ² (3,410 psi)
Pilot circuit	35 kgf/cm ² (500 psi)
Service valve	Installed
Hydraulic cylinders	
No. of cylinder-bore × rod × stroke	Boom: 2-120 × 85 × 1290 mm (4.7" × 3.3" × 50.8")
	Arm: 1-140 × 100 × 1510 mm (5.5" × 3.9" × 59.4")
	Bucket: 1-125 × 85 × 1055 mm (4.9" × 3.3" × 41.5")



Drives & Brakes

Drive method	Fully hydrostatic type
Drive motor	Axial piston motor, in-shoe design
Reduction system	STD/HC Planetary reduction gear
Max. drawbar pull	21,100 kgf (46,500 lbf)
Max. travel speed(high) / (low)	5.3 km/hr (3.3 mph) / 3.4 km/hr (2.1 mph)
Gradeability	35° (70 %)
Parking brake	Multi wet disc



Control

Pilot pressure operated joysticks and pedals with detachable lever provide almost effortless and fatigueless operation.

Pilot control	Two joysticks with one safety lever (LH): Swing and arm, (RH): Boom and bucket(ISO)
Traveling and steering	Two levers with pedals
Engine throttle	Electric, Dial type
Lights	Two lights mounted on the boom and one in the battery box



Swing system

Swing motor	Axial piston motor
Swing reduction	Planetary gear reduction
Swing bearing lubrication	Grease-bathed
Swing brake	Multi wet disc
Swing speed	12.5 rpm



Coolant & Lubricant capacity

(refilling)	liter	US gal	UK gal
Fuel tank	340	89.8	74.8
Engine coolant	35	9.2	7.7
Engine oil	24	6.3	5.3
Swing device	5	1.3	1.1
Final drive(each)	STD/HC	5.8	2
Hydraulic system(including tank)	290	76.6	63.8
Hydraulic tank	180	47.6	39.6



Undercarriage

X-leg type center frame is integrally welded with reinforced box-section track frames. The undercarriage includes lubricated rollers, idlers, track adjusters with shock absorbing spring and sprockets, and track chain with double or triple grouser shoes.

Center frame	X - leg type
Track frame	Pentagonal box type
No. of shoes on each side	49
No. of carrier roller on each side	2
No. of track roller on each side	9
No. of rail guard on each side	2



Operating weight (approximate)

Operating weight, including 5680mm (18' 8") boom, 2920m (9' 7") arm, SAE heaped 0.92m³ (1.20 yd³) backhoe bucket, lubricant, coolant, full fuel tank, hydraulic tank and the standard equipment.

Major component weight

Upperstructure	5,850kg (12,900lb)
Counterweight	3,800kg (8,380lb)
Boom (with Arm cylinder)	1,950kg (4,300lb)

Operating weight

Type	Shoes		Operating weight		Ground pressure
	Width mm(in)		kg(lb)	kgf/cm ² (psi)	
Triple grouser	※ 600 mm (24")	R210LC-7	21,700 (47,800)	0.46 (6.54)	
		R210LC-7 H/C	23,160 (51,060)	0.49 (6.97)	
	700 mm (28")	R210LC-7	21,980 (48,460)	0.40 (5.69)	
		R210LC-7 H/C	23,440 (51,680)	0.43 (6.12)	
	800 mm (32")	R210LC-7	22,270 (49,070)	0.35 (4.98)	
		R210LC-7 H/C	23,730(52,320)	0.38 (5.40)	
900 mm (35.4")	R210LC-7	22,560 (49,740)	0.32 (4.55)		
	Double grouser	710 mm (28")	R210LC-7 H/C	23,770 (52,400)	0.43 (6.12)

※ Standard equipment



Buckets

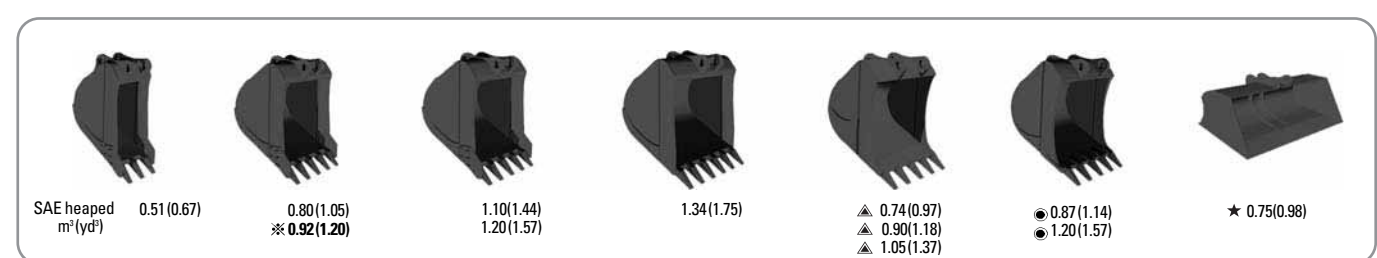

Capacity m ³ (yd ³)	Width mm (in)	Weight kg(lb)	Recommendation mm(ft.in)			
			2,000 (6' 7")	2,400 (7' 10")	※ 2,920 (9' 7")	3,900 (12' 10")
0.51(0.67)	700(27.6)	570(1260)	●	●	●	●
0.80(1.05)	1000(39.4)	700(1540)	●	●	●	■
※ 0.92(1.20)	1150(45.3)	770(1700)	●	●	■	▲
1.10(1.44)	1320(52.0)	830(1830)	■	▲	▲	-
1.20(1.57)	1400(55.1)	850(1870)	■	▲	-	-
1.34(1.75)	1550(61.0)	920(2030)	▲	▲	-	-
▲ 0.74(0.97)	985(38.8)	770(1700)	●	●	●	▲
▲ 0.90(1.18)	1070(42.0)	810(1790)	●	●	■	-
▲ 1.05(1.37)	1290(50.8)	890(1960)	■	▲	-	-
● 0.87(1.14)	1140(44.9)	900(1980)	●	●	■	-
● 1.20(1.57)	1410(55.5)	1030(2270)	■	▲	-	-
★ 0.75(0.98)	1790(70.5)	880(1940)	●	●	■	▲

※ : Standard backhoe bucket

▲ : Heavy-duty

● : Rock bucket-Heavy duty

★ : Slope finishing bucket

● Applicable for materials with density of 2,000 kg / m³ (3,370 lb/ yd³) or less

■ Applicable for materials with density of 1,600 kg / m³ (2,700 lb/ yd³) or less

▲ Applicable for materials with density of 1,100 kg / m³ (1,850 lb/ yd³) or less



Backhoe attachment

Boom and arms are of all-welded, low-stress, full-box section design. 5.68m(18' 8") mono boom and 2.0m(6' 7"), 2.4m (7' 10"), 2.92m (9' 7"), 3.90m (12' 10") arm are available. Buckets are all-welded, high-strength steel implements.

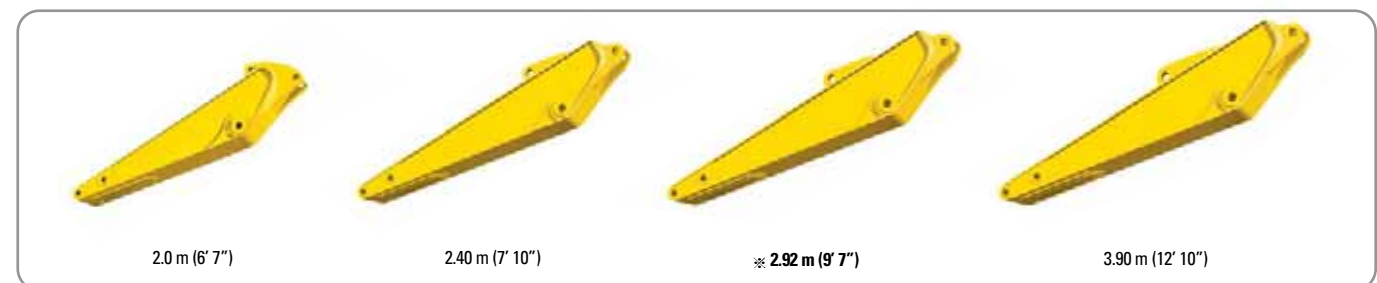

Digging force

Arm	Length	mm(ft.in)	2,000 (6' 7")	2,400 (7' 10")	※ 2,920 (9' 7")	3,900 (12' 10")	Remark
			Weight	kg(lb)	950 (2,090)	990 (2,180)	
Bucket digging force	SAE	kN	133.4 [145.5]	133.4 [145.5]	133.4 [145.5]	133.4 [145.5]	[] : Power Boost
		kgf lbf	13600 [14840]	13600 [14840]	13600 [14840]	13600 [14840]	
	ISO	kN	152.0 [165.8]	152.0 [165.8]	152.0 [165.8]	152.0 [165.8]	
		kgf lbf	15500 [16910]	15500 [16910]	15500 [16910]	15500 [16910]	
Arm crowd force	SAE	kN	135.3 [147.6]	112.8 [123.1]	97.1 [105.9]	79.4 [86.6]	
		kgf lbf	13800 [15050]	11500 [12550]	9900 [10800]	8100 [8840]	
	ISO	kN	142.2 [155.1]	117.7 [128.4]	101.0 [110.2]	85.3 [93.0]	
		kgf lbf	14500 [15820]	12000 [13090]	10300 [11240]	8700 [9490]	

Note : Arm weight including bucket cylinder and linkage.

※ Standard arm

Dimensions & Working ranged

Dimensions R210LC-7

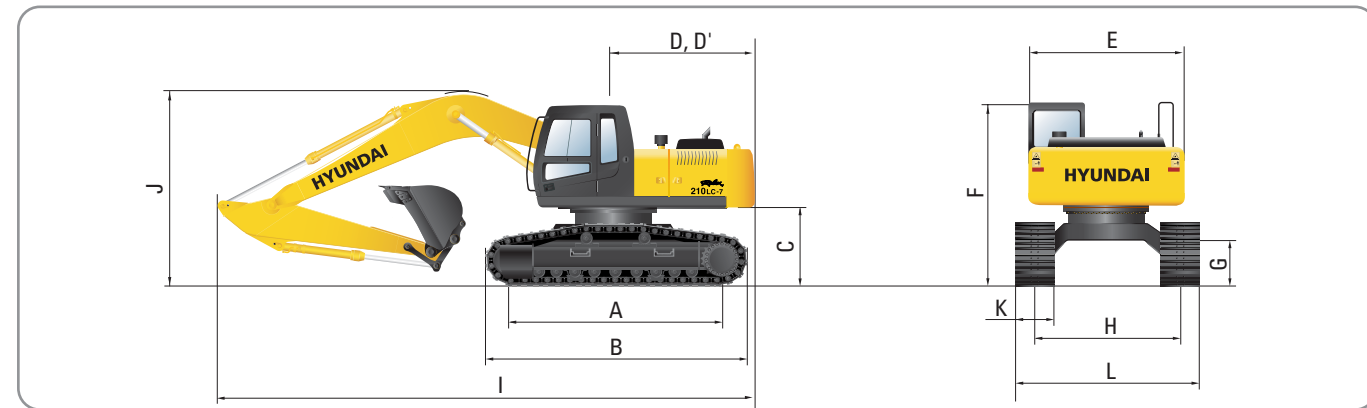

		mm (ft · in)
A	Tumbler distance	3,650 (12' 0")
B	Overall length of crawler	4,440 (14' 7")
C	Ground clearance of counterweight	1,060 (3' 6")
D	Tail swing radius	2,830 (9' 3")
D'	Rear-end length	2,770 (9' 1")
E	Overall width of upperstructure	2,700 (8' 10")
F	Overall height of cab	2,920 (9' 7")
G	Min. ground clearance	480 (1' 7")
H	Track gauge	2,390 (7' 10")

		mm (ft · in)			
	Boom length	※5,680 (18' 8")			
	Arm length	2,000 (6' 7")	2,400 (7' 10")	※2,920 (9' 7")	3,900 (12' 10")
I	Overall length	9,650 (31' 8")	9,570 (31' 5")	9,520 (31' 3")	9,520 (31' 3")
J	Overall height of boom	3,200 (10' 6")	3,110 (10' 2")	2,990 (9' 10")	3,480 (11' 5")
K	Track shoe width	600 (24")	700 (28")	800 (32")	900 (35.4")
L	Overall width	2,990 (9' 10")	3,090 (10' 2")	3,190 (10' 6")	3,290 (10' 10")

※Standard Equipment

Dimensions R210LC-7 High Chassis

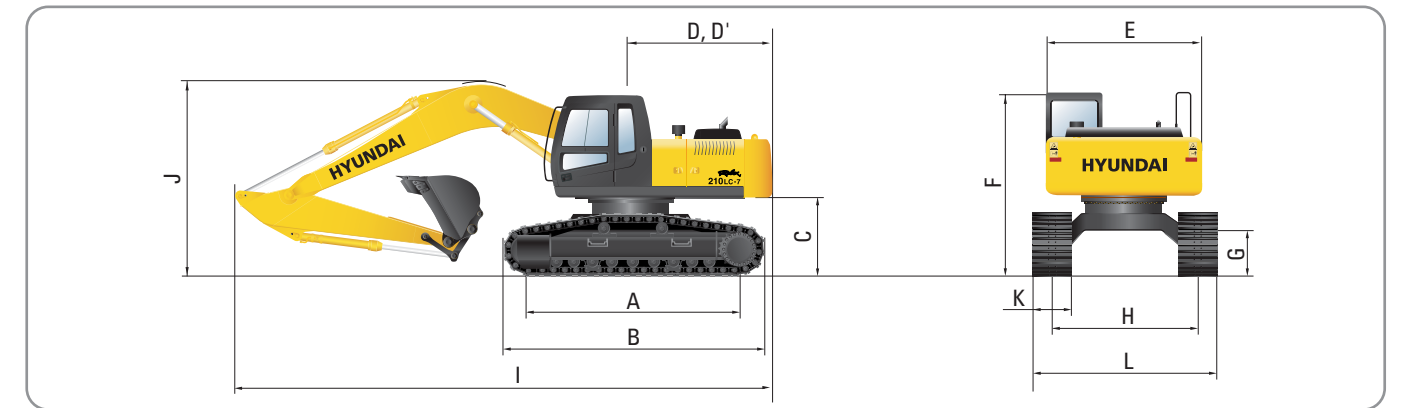

		mm (ft · in)	
A	Tumbler distance	3,650 (12' 0")	
B	Overall length of crawler	4,440 (14' 7")	
C	Ground clearance of counterweight	1,260 (4' 2")	
D	Tail swing radius	2,830 (9' 3")	
D'	Rear-end length	2,770 (9' 1")	
E	Overall width of upperstructure	2,700 (8' 10")	
F	Overall height of cab	3,100 (10' 2")	
G	Min. ground clearance	660 (2' 2")	
H	Track gauge	2,795 (9' 2")	

		mm (ft · in)			
	Boom length	※5,680 (18' 8")			
	Arm length	2,000 (6' 7")	2,400 (7' 10")	※2,920 (9' 7")	3,900 (12' 10")
I	Overall length	9,640 (31' 7")	9,550 (31' 4")	9,470 (31' 1")	9,560 (31' 4")
J	Overall height of boom	3,320 (10' 11")	3,220 (10' 7")	3,080 (10' 1")	3,490 (11' 5")
K	Track shoe width	Type	Triple grouser		Double grouser
		width	※600 (24")	700 (28")	800 (32")
					710 (28")
L	Overall width		3,395 (11' 2")	3,495 (11' 6")	3,595 (12' 0")

※Standard Equipment

Working ranges R210LC-7

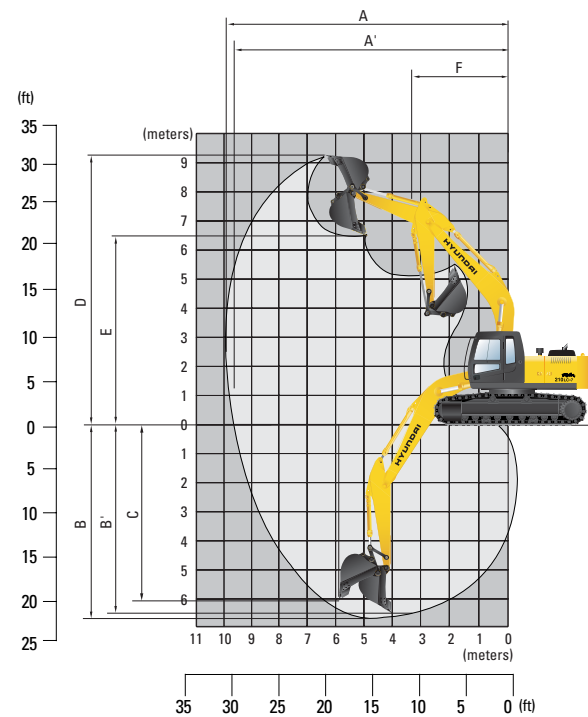

		mm (ft · in)			
	Boom length	※5,680 (18' 8")			
	Arm length	2,000 (6' 7")	2,400 (7' 10")	※2,920 (9' 7")	3,900 (12' 10")
A	Max. digging reach	9,140 (30' 0")	9,500 (31' 2")	9,940 (32' 7")	10,910 (35' 10")
A'	Max. digging reach on ground	8,960 (29' 5")	9,330 (30' 7")	9,780 (32' 1")	10,770 (35' 4")
B	Max. digging depth	5,820 (19' 1")	6,220 (20' 5")	6,740 (22' 1")	7,720 (25' 4")
B'	Max. digging depth (8' level)	5,580 (18' 4")	6,010 (19' 9")	6,550 (21' 6")	7,580 (24' 10")
C	Max. vertical wall digging depth	5,280 (17' 4")	5,720 (18' 9")	6,120 (20' 1")	7,240 (23' 9")
D	Max. digging height	9,140 (30' 0")	9,340 (30' 8")	9,470 (31' 1")	10,110 (33' 2")
E	Max. dumping height	6,330 (20' 9")	6,520 (21' 5")	6,670 (21' 11")	7,290 (23' 11")
F	Min. swing radius	3,750 (12' 4")	3,740 (12' 3")	3,640 (11' 11")	3,650 (11' 12")

※Standard Equipment

Working ranges R210LC-7 High Chassis

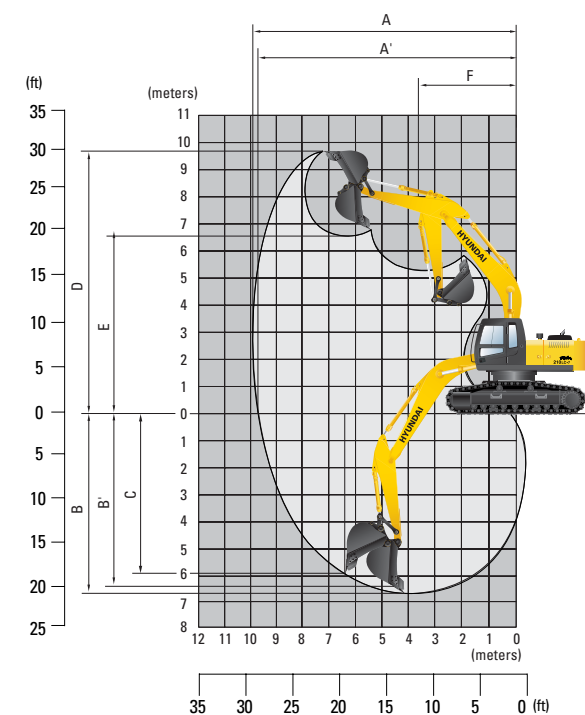

		mm (ft · in)			
	Boom length	※5,680 (18' 8")			
	Arm length	2,000 (6' 7")	2,400 (7' 10")	※2,920 (9' 7")	3,900 (12' 10")
A	Max. digging reach	9,140 (30' 0")	9,500 (31' 2")	9,940 (32' 7")	10,910 (35' 10")
A'	Max. digging reach on ground	8,920 (29' 3")	9,290 (30' 6")	9,740 (31' 11")	10,730 (35' 2")
B	Max. digging depth	5,630 (18' 6")	6,010 (19' 9")	6,550 (21' 6")	7,530 (24' 8")
B'	Max. digging depth (8' level)	5,390 (17' 8")	5,820 (19' 1")	6,360 (20' 10")	7,390 (24' 3")
C	Max. vertical wall digging depth	5,090 (16' 8")	5,530 (18' 2")	5,930 (19' 5")	7,050 (23' 1")
D	Max. digging height	9,330 (30' 7")	9,530 (31' 3")	9,660 (31' 8")	10,300 (33' 9")
E	Max. dumping height	6,520 (21' 5")	6,710 (22' 0")	6,860 (22' 6")	7,480 (24' 6")
F	Min. swing radius	3,750 (12' 4")	3,740 (12' 3")	3,640 (11' 11")	3,650 (11' 12")

※Standard Equipment

Lifting Capacities



Lifting capacities R210LC-7



Rating over-front



Rating over-side or 360 degree

• Boom : 5.68m (18' 8") • Arm : 2.0 m (6' 7") • Bucket : 0.92 m³ (1.20 yd³) SAE heaped • Shoe : 600mm(24") triple grouser with 3,800kg (8,380 lb) counterweight

Load point height m(ft)		Load radius								At max. reach		
		3.0 m (10.0 ft)		4.5 m (15.0 ft)		6.0 m (20.0 ft)		7.5 m (25.0 ft)		Capacity		Reach
												m (ft)
7.5 m (25.0 ft)	kg									*3750	*3750	6.64
	lb									*8270	*8270	(21.8)
6.0 m (20.0 ft)	kg					*4150	*4150			*3800	3060	7.78
	lb					*9150	*9150			*8380	6750	(25.5)
4.5 m (15.0 ft)	kg			*5360	*5360	*4540	*4540			*3910	2560	8.43
	lb			*11820	*11820	*10010	*10010			*8620	5640	(27.7)
3.0 m (10.0 ft)	kg			*6970	6830	*5240	4380	*4500	3020	*4050	2340	8.74
	lb			*15370	15060	*11550	9660	*9920	6660	*8930	5160	(28.7)
1.5 m (5.0 ft)	kg			*8380	6310	*5950	4120	*4820	2900	4000	2280	8.73
	lb			*18470	13910	*13120	9080	*10630	6390	8820	5030	(28.6)
Ground Line	kg			*9020	6080	*6430	3960	4980	2830	4210	2400	8.42
	lb			*19890	13400	*14180	8730	10980	6240	9280	5290	(27.6)
-1.5 m (-5.0 ft)	kg	*13020	12190	*8960	6050	*6510	3910			*4550	2770	7.76
	lb	*28700	26870	*19750	13340	*14350	8620			*10030	6110	(25.5)
-3.0 m (-10.0 ft)	kg	*11620	*11620	*8210	6160	*5910	3990			*4510	3660	6.61
	lb	*25620	*25620	*18100	13580	*13030	8800			*9940	8070	(21.7)
-4.5 m (-15.0 ft)	kg	*8770	*8770									
	lb	*19330	*19330									

• Boom : 5.68m (18' 8") • Arm : 2.4 m (7' 10") • Bucket : 0.92 m³ (1.20 yd³) SAE heaped • Shoe : 600mm(24") triple grouser with 3,800kg (8,380 lb) counterweight

Load point height m(ft)		Load radius								At max. reach				
		1.5 m (5.0 ft)		3.0 m (10.0 ft)		4.5 m (15.0 ft)		6.0 m (20.0 ft)		7.5 m (25.0 ft)		Capacity		Reach
														m (ft)
7.5 m (25.0 ft)	kg											*3630	3190	7.15
	lb											*8000	7030	(23.5)
6.0 m (20.0 ft)	kg							*3750	*3750			*3520	2490	8.20
	lb							*8270	*8270			*7760	5490	(26.9)
4.5 m (15.0 ft)	kg							*4190	*4190	*3940	3140	*3450	2200	8.82
	lb							*9240	*9240	*8690	6920	*7610	4850	(28.9)
3.0 m (10.0 ft)	kg					*6420	*6420	*4920	4400	*4240	3020	3770	2100	9.11
	lb					*14150	*14150	*10850	9700	*9350	6660	8310	4630	(29.9)
1.5 m (5.0 ft)	kg					*7960	6360	*5690	4130	*4620	2890	3720	2150	9.10
	lb					*17550	14020	*12540	9110	*10190	6370	8200	4740	(29.9)
Ground Line	kg			*8300	*8300	*8820	6050	*6260	3930	*4920	2790	3890	2350	8.81
	lb			*18300	*18300	*19440	13340	*13800	8660	*10850	6150	8580	5180	(28.9)
-1.5 m (-5.0 ft)	kg	*9220	*9220	*12750	11960	*8970	5970	*6460	3850			*4300	2780	8.18
	lb	*20330	*20330	*28110	26370	*19780	13160	*14240	8490			*9480	6130	(26.8)
-3.0 m (-10.0 ft)	kg	*13340	*13340	*12280	12180	*8430	6040	*6110	3890			*4360	*3450	7.12
	lb	*29410	*29410	*27070	26850	*18580	13320	*13470	8580			*9610	*7610	(23.4)
-4.5 m (-15.0 ft)	kg			*9840	*9840	*6850	6300							
	lb			*21690	*21690	*15100	13890							

• Boom : 5.68m (18' 8") • Arm : 2.92 m (9' 7") • Bucket : 0.92 m³ (1.20 yd³) SAE heaped • Shoe : 600mm(24") triple grouser with 3,800kg (8,380 lb) counterweight

Load point height m(ft)		Load radius								At max. reach						
		1.5 m (5.0 ft)		3.0 m (10.0 ft)		4.5 m (15.0 ft)		6.0 m (20.0 ft)		7.5 m (25.0 ft)		Capacity		Reach		
														m (ft)		
7.5 m (25.0 ft)	kg											*3120	*3120	7.72		
	lb											*6880	*6880	(25.3)		
6.0 m (20.0 ft)	kg											*3210	2530	8.69		
	lb											*7080	5580	(28.5)		
4.5 m (15.0 ft)	kg							*3770	*3770	*3590	3210	*3340	2170	9.27		
	lb							*8310	*8310	*7910	7080	*7360	4780	(30.4)		
3.0 m (10.0 ft)	kg					*9160	*9160	*5760	*5760	*4530	4490	*3490	1980	9.55		
	lb					*20190	*20190	*12700	*12700	*9990	9900	*8710	6770	*7690	4370	(31.3)
1.5 m (5.0 ft)	kg					*8660	*8660	*7430	6550	*5380	4180	*4390	2910	3440	1930	9.54
	lb					*19090	*19090	*16380	14330	*11860	9220	*9680	6420	7580	4250	(31.3)
Ground Line	kg			*9310	*9310	*8550	6100	*6060	3950	*4770	2780	3580	2000	9.26		
	lb			*20530	*20530	*18850	13450	*13360	8710	*105520	6130	7890	4410	(30.4)		
-1.5 m (-5.0 ft)	kg	*8550	*8550	*12160	11830	*8950	5940	*6400	3820	4870	2720	3970	2230	8.67		
	lb	*18850	*18850	*26810	26080	*19730	13100	*14110	8420	10740	6000	8750	4920	(28.4)		
-3.0 m (-10.0 ft)	kg	*11700	*11700	*13020	11990	*8680	5960	*6280	3820			*4230	2770	7.69		
	lb	*25790	*25790	*28700	26430	*19140	13140	*13850	8420			*9330	6110	(25.2)		
-4.5 m (-15.0 ft)	kg			*11040	*11040	*7560	6130					*4140	*4140	6.09		
	lb			*24340	*24340	*16670	13510					*9130	*9130	(20.0)		

• Boom : 5.68m (18' 8") • Arm : 3.9 m (12' 9") • Bucket : 0.92 m³ (1.20 yd³) SAE heaped • Shoe : 600mm(24") triple grouser with 3,800kg (8,380 lb) counterweight

Load point height m(ft)		Load radius										At max. reach						
		1.5 m (5.0 ft)		3.0 m (10.0 ft)		4.5 m (15.0 ft)		6.0 m (20.0 ft)		7.5 m (25.0 ft)		9.0 m (30.0 ft)		Capacity		Reach		
																m (ft)		
9.0 m (30.0 ft)	kg															*2590	*2590	7.66
	lb															*5710	*5710	(25.1)
7.5 m (25.0 ft)	kg															*2640	2470	8.94
	lb															*5820	5450	(29.3)
6.0 m (20.0 ft)	kg															*2670	2010	9.77
	lb															*5890	*5890	(32.1)
4.5 m (15.0 ft)	kg															*2910	*2910	10.28
	lb															*6420	*6420	(33.7)
3.0 m (10.0 ft)	kg															*3710	*3710	10.52
	lb															*8180	*8180	(34.5)
1.5 m (5.0 ft)	kg															*3340	3130	10.52
	lb															*7360	6900	(34.5)
Ground Line	kg															*4950	*4950	10.27
	lb															*10910	*10910	(33.7)
-1.5 m (-5.0 ft)	kg	*7060	*7060	*10980	*10980	*8560	5860	*6070	3750	*4710	2640	*2240	1950	3220	1760	9.75		
	lb	*15560	*15560	*24210	*24210	*18870	12920	*13380	8270	*10380	5820	*4940	4300	7100	3880	(32.0)		
-3.0 m (-10.0 ft)	kg	*9410	*9410	*13520	11550	*8760	5760	*6270	3670	4750	2600			*3650	2080	8.91		
	lb	*20750	*20750	*29810	25460	*19310	12700	*13820	8090	10470	5730			*8050	4590	(29.2)		
-4.5 m (-15.0 ft)	kg	*12210	*12210	*12480	11790	*8250	5830	*5920	3720					*3770	2770	7.62		
	lb	*26920	*26920	*27510	25990	*18190	12850	*13050	8200					*8310	6110	(25.0)		
6.0 m (20.0 ft)	kg															*9890	*9890	
	lb															*21800	*21800	

• Boom : 5.68m (18' 8") • Arm : 2.0 m (6' 7") • Bucket : 0.92 m³ (1.20 yd³) SAE heaped • Shoe : 800mm(32") triple grouser with 3,800kg (8,380 lb) counterweight

Load point height m(ft)		Load radius						At max. reach						
		3.0 m (10.0 ft)		4.5 m (15.0 ft)		6.0 m (20.0 ft)		7.5 m (25.0 ft)		Capacity		Reach		
												m (ft)		
7.5 m (25.0 ft)	kg											*3750	*3750	6.64
	lb											*8270	*8270	(21.8)
6.0 m (20.0 ft)	kg											*4150	*4150	7.78
	lb											*9150	*9150	(25.5)
4.5 m (15.0 ft)	kg													

Lifting Capacities

• **Boom** : 5.68m (18' 8") • **Arm** : 2.92 m (9' 7") • **Bucket** : 0.92 m³ (1.20 yd³) SAE heaped • **Shoe** : 800mm(32") triple grouser with 3,800kg (8,380 lb) counterweight

Load point height m(ft)	Load radius										At max. reach			
	1.5 m (5.0 ft)		3.0 m (10.0 ft)		4.5 m (15.0 ft)		6.0 m (20.0 ft)		7.5 m (25.0 ft)		Capacity		Reach	
													m (ft)	
7.5 m (25.0 ft)	kg											*3120	*3120	7.72
	lb											*6880	*6880	(25.3)
6.0 m (20.0 ft)	kg											*3210	2600	8.69
	lb											*7080	5730	(28.5)
4.5 m (15.0 ft)	kg						*3770	*3770	*3590	3300	*3340	2230	4920	9.27
	lb						*8310	*8310	*7910	7280	*7360	4920	2230	(30.4)
3.0 m (10.0 ft)	kg			*9160	*9160	*5760	*5760	*4530	*4530	*3950	3160	*3490	2050	9.55
	lb			*20190	*20190	*12700	*12700	*9990	*9990	*8710	6970	*7690	4520	(31.3)
1.5 m (5.0 ft)	kg			*8660	*8660	*7430	6670	*5380	4300	*4390	3000	3550	2000	9.54
	lb			*19090	*19090	*16380	14700	*11860	9480	*9680	6610	7830	4410	(31.3)
Ground Line	kg			*9310	*9310	*8550	6270	*6060	4060	*4770	2870	3690	2070	9.26
	lb			*20530	*20530	*18850	13820	*13360	8950	*10520	6330	8140	4560	(30.4)
-1.5 m (-5.0 ft)	kg	*8550	*8550	*12160	12150	*8950	6110	*6400	3940	*4940	2810	*4070	2310	8.67
	lb	*18850	*18850	*26810	26790	*19730	13470	*14110	8690	*10890	6190	*8970	5090	(28.4)
-3.0 m (-10.0 ft)	kg	*11700	*11700	*13020	12310	*8680	6130	*6280	3930			*4230	2850	7.69
	lb	*25790	*25790	*28700	27140	*19140	13510	*13850	8660			*9330	6280	(25.2)
-4.5 m (-15.0 ft)	kg			*11040	*11040	*7560	6300					*4140	*4140	6.09
	lb			*24340	*24340	*16670	13890					*9130	*9130	(20.0)

• **Boom** : 5.68m (18' 8") • **Arm** : 3.9 m (12' 9") • **Bucket** : 0.92 m³ (1.20 yd³) SAE heaped • **Shoe** : 800mm(32") triple grouser with 3,800kg (8,380 lb) counterweight

Load point height m(ft)	Load radius										At max. reach					
	1.5 m (5.0 ft)		3.0 m (10.0 ft)		4.5 m (15.0 ft)		6.0 m (20.0 ft)		7.5 m (25.0 ft)		9.0 m (30.0 ft)		Capacity	Reach		
															m (ft)	
9.0 m (30.0 ft)	kg												*2590	*2590	7.66	
	lb												*5710	*5710	(25.1)	
7.5 m (25.0 ft)	kg								*1870	*1870			*2640	2550	8.94	
	lb								*4120	*4120			*5820	5620	(29.3)	
6.0 m (20.0 ft)	kg								*2670	*2670			*2720	2080	9.77	
	lb								*5890	*5890			*6000	4590	(32.1)	
4.5 m (15.0 ft)	kg								*2910	*2910	*1930	*1930	*2830	1810	10.28	
	lb								*6420	*6420	*4250	*4250	*6240	3990	(33.7)	
3.0 m (10.0 ft)	kg							*3710	*3710	*3340	3220	*2750	2270	*2960	1670	10.52
	lb							*8180	*8180	*7360	7100	*6060	5000	*6530	3680	(34.5)
1.5 m (5.0 ft)	kg			*10430	*10430	*6230	*6230	*4640	4390	*3860	3020	*3260	2160	2990	1620	10.52
	lb			*22990	*22990	*13730	*13730	*10230	9680	*8510	6660	*7190	4760	6590	3570	(34.5)
Ground Line	kg	*4950	*4950	*9990	*9990	*7720	6340	*5490	4070	*4360	2850	*3340	2070	3070	1670	10.27
	lb	*10910	*10910	*22020	*22020	*17020	13980	*12100	8970	*9610	6280	*7360	4560	6770	3680	(30.2)
-1.5 m (-5.0 ft)	kg	*7060	*7060	*10980	*10980	*8560	6030	*6070	3870	*4710	2730	*2240	2020	3330	1820	9.75
	lb	*15560	*15560	*24210	*24210	*18870	13290	*13380	8530	*10380	6020	*4940	4450	7340	4010	(32.0)
-3.0 m (-10.0 ft)	kg	*9410	*9410	*13520	11870	*8760	5930	*6270	3790	*4780	2680			*3650	2150	8.91
	lb	*20750	*20750	*29810	26170	*19310	13070	*13820	8360	*10540	5910			*8050	4740	(29.2)
-4.5 m (-15.0 ft)	kg	*12210	*12210	*12480	12100	*8250	6000	*5920	3830					*3770	2860	7.62
	lb	*26920	*26920	*27510	26680	*18190	13230	*13050	8440					*8310	6310	(25.0)
6.0 m (20.0 ft)	kg			*9890	*9890	*6620	6280									
	lb			*21800	*21800	*14590	13850									

Lifting capacities R210LC-7 High Chassis

Rating over-front Rating over-side or 360 degree

• **Boom** : 5.68m (18' 8") • **Arm** : 2.0 m (6' 7") • **Bucket** : 0.92 m³ (1.20 yd³) SAE heaped • **Shoe** : 600mm(24") triple grouser with 3,800kg (8,380 lb) counterweight

Load point height m(ft)	Load radius						At max. reach					
	3.0 m (10.0 ft)		4.5 m (15.0 ft)		6.0 m (20.0 ft)		7.5 m (25.0 ft)		Capacity	Reach		
											m (ft)	
7.5 m (25.0 ft)	kg								*3750	*3750	6.82	
	lb								*8270	*8270	(22.4)	
6.0 m (20.0 ft)	kg					*4170	*4170		*3810	*3810	7.88	
	lb					*9190	*9190		*8400	*8400	(25.9)	
4.5 m (15.0 ft)	kg	*8080	*8080	*5550	*5550	*4620	*4620		*3920	*3800	8.49	
	lb	*17810	*17810	*12240	*12240	*10190	*10190		*8640	7230	(27.9)	
3.0 m (10.0 ft)	kg			*7170	*7170	*5330	*5330	*4540	3900	*4070	3050	8.75
	lb			*15810	*15810	*11750	*11750	*10010	8600	*8970	6720	(28.7)
1.5 m (5.0 ft)	kg			*8510	8290	*6030	5350	*4860	3790	*4250	3020	8.71
	lb			*18760	18280	*13290	11790	*10710	8360	*9370	6660	(28.6)
Ground Line	kg			*9050	8080	*6470	5190	*5050	3720	*4430	3210	8.36
	lb			*19950	17810	*14260	11440	*11130	8200	*9770	7080	(27.4)
-1.5 m (-5.0 ft)	kg	*12900	*12900	*8910	8070	*6480	5150			*4560	3710	7.64
	lb	*28440	*28440	*19640	17790	*14290	11350			*10050	8180	(25.1)
-3.0 m (-10.0 ft)	kg	*11370	*11370	*8040	*8040					*4470	*4470	6.41
	lb	*25070	*25070	*17730	*17730					*9850	*9850	(21.0)

• **Boom** : 5.68m (18' 8") • **Arm** : 2.4 m (7' 10") • **Bucket** : 0.92 m³ (1.20 yd³) SAE heaped • **Shoe** : 600mm(24") triple grouser with 3,800kg (8,380 lb) counterweight

Load point height m(ft)	Load radius										At max. reach				
	1.5 m (5.0 ft)		3.0 m (10.0 ft)		4.5 m (15.0 ft)		6.0 m (20.0 ft)		7.5 m (25.0 ft)		Capacity		Reach		
													m (ft)		
7.5 m (25.0 ft)	kg												*3650	4350	6.94
	lb												*8050	9590	(22.8)
6.0 m (20.0 ft)	kg												*3530	3360	8.07
	lb												*7780	7410	(26.5)
4.5 m (15.0 ft)	kg												*3780	*3780	8.75
	lb												*8330	*8330	(28.7)
3.0 m (10.0 ft)	kg												*5010	*5010	9.08
	lb												*11050	*11050	(29.8)
1.5 m (5.0 ft)	kg												*6640	*6640	9.12
	lb												*14640	*14640	(29.9)
Ground Line	kg												*8110	*8110	9.26
	lb												*17880	*17880	(30.4)
-1.5 m (-5.0 ft)	kg	*9710	*9710	*13370	*13370	*8940	7970	*6460	5090				*4320	3500	8.30
	lb	*21410	*21410	*29480	*29480	*19710	17570	*14240	11220				*9520	7720	(27.2)
-3.0 m (-10.0 ft)	kg	*13920	*13920	*12060	*12060	*8310	8070	*6000	5150				*4350	*3460	7.31
	lb	*30690	*30690	*26590	*26590	*18320	17790	*13230	11350				*9590	*7630	(24.0)
-4.5 m (-15.0 ft)	kg					*9390	*9390	*6500	*6500						
	lb					*20700	*20700	*14330	*14330						

• **Boom** : 5.68m (18' 8") • **Arm** : 2.92 m (9' 7") • **Bucket** : 0.92 m³ (1.20 yd³) SAE heaped • **Shoe** : 600mm(24") triple grouser with 3,800kg (8,380 lb) counterweight

Load point height m(ft)	Load radius										At max. reach		
	1.5 m (5.0 ft)		3.0 m (10.0 ft)		4.5 m (15.0 ft)		6.0 m (20.0 ft)		7.5 m (25.0 ft)		Capacity		Reach